



GREATER NY
DENTAL MEETING.

2024

100 YEARS

OF GREATNESS & GRATITUDE

2024

GREATER NEW YORK DENTAL MEETING™

Jacob K. Javits Convention Center, New York City

THE LARGEST DENTAL MEETING IN THE UNITED STATES



MEETING DATES:

| | |
|----------|----|
| NOVEMBER | 29 |
| DECEMBER | 4 |

EXHIBIT DATES:

| | |
|----------|---|
| DECEMBER | 1 |
| DECEMBER | 4 |

EXHIBITOR PROSPECTUS

JACOB K. JAVITS CONVENTION CENTER OF NEW YORK

GNYDM 2024

MEETING DATES

Friday, November 29 -
Wednesday, December 4

EXHIBIT DATES

Sunday, December 1 -
Wednesday, December 4

JOHN J. YOUNG, JR., D.M.D.
General Chair

MR. TOM LOUGHRAN
General Manager

MS. CARLA M. BORG
Exhibits Manager

MS. DANA A. SOLTIS
Sponsorship & Advertising Manager

Co-Sponsored by the
SECOND DISTRICT DENTAL SOCIETY
and the
NEW YORK COUNTY DENTAL SOCIETY
of the State of New York

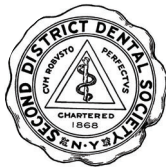

EXECUTIVE OFFICE:

200 West 41st Street - Suite 1101 | New York, NY 10036-7203, USA

Phone (212) 398-6922 | Fax (212) 398-6934

E-mail: carla@gnydm.com | Website: www.gnydm.com

THE FOLLOWING RULES & REGULATIONS GOVERN EXHIBITS AT THE
100th ANNUAL GREATER NEW YORK DENTAL MEETING. PLEASE READ CAREFULLY.

Exhibitor Prospectus

| | |
|---|---------------------------------|
| Application & Payment for Space..... 4 | Exhibit Dates & Hours..... 5 |
| Cancellation or Reduction of Space..... 5 | Exhibit Dismantling 6 |
| Charges for Space 4 | Exhibit Set-up 5 |
| Checklist of Important Dates 15 | Exhibit Space Assignment..... 8 |
| Conference Rooms 4 | Exhibitor’s Calendar 15 |
| Contract for Space 13 | Special Program..... 12 |



Total Registrants
36,081



Dentists
13,302



Dental Assistants
2,027



Dental Hygienists
2,320



Countries
139

SIGN UP EARLY AND SAVE

*** TAKE ADVANTAGE OF DISCOUNTED BOOTH PRICES BEFORE THEY INCREASE**

| BOOTH SIZE | *2024 EARLY BIRD RATES NOV. 29 - JAN. 15 | RATES UNTIL JAN. 15 - MAR. 15 | RATES AFTER MAR. 15 |
|---------------------|---|----------------------------------|------------------------|
| 8x10 | \$4,050.00 | \$4,110.00 | \$4,170.00 |
| 8x10 Corner | \$4,660.00 | \$4,730.00 | \$4,800.00 |
| 10x10 | \$5,065.00 | \$5,140.00 | \$5,215.00 |
| 10x10 Corner | \$5,800.00 | \$5,890.00 | \$5,975.00 |
| 10x15 (2) | \$7,555.00 | \$7,670.00 | \$7,785.00 |
| Extras | | | |
| Conference Room | \$3,630.00 | \$3,685.00 | \$3,740.00 |
| Executive Suite | \$8,995.00 | \$9,130.00 | \$9,300.00 |
| 10x10 DCR | \$1,150.00 | \$1,170.00 | \$1,190.00 |
| 10x20 DCR | \$1,760.00 | \$1,790.00 | \$1,800.00 |
| *NO INCREASE | | | |

Instructions: Submit this Application, with \$1,100.00 deposit per each 10' x 10' booth (NON-REFUNDABLE). Deposits can be made by check, wire transfer or credit card. Final payment is due on or before June 2. Full payment must accompany contracts submitted after June 2. Valid Certificate of Insurance is required. Full payment is required for international companies. The company name, address, city, state/country, customer service phone, fax numbers, E-mail, and Website address as shown on this form are for use in the Program and Exhibit Guide for Applications received Prior to June15.

**Company Listing in
Printed &
Digital Platforms
Year Round**

**Complimentary
New Product &
Technology Pavilion**

**U.S. Dept. of Commerce
at-show
market counseling**

**Multiple Sponsorship
&
Advertising Opportunities**

1. APPLICATION/CONTRACT FOR SPACE

An Application/Contract for exhibit space at its 2024 Meeting must be made in writing to the Greater New York Dental Meeting Organization Committee (the "Committee"), and must be accompanied by a deposit of \$1,100.00 for each 10 x 10 booth space requested prior to June 2, 2024 or full payment thereafter. No Application/Contract will be considered unless accompanied by said payment. The Exhibitor's properly signed Application/Contract, together with Certificate of Insurance and the appropriate payment must be returned to:

Ms. Carla Borg, Exhibits Manager
Greater New York Dental Meeting
200 West 41st Street- Suite 1101
New York, NY 10036-7203

Exhibit space shall be assigned solely by the Committee. The Committee at its discretion, accepts or rejects applications for booth space.

Applicants are advised that final confirmation of exhibit space may be delayed due to the volume of applications received at the time of submission and deposit of the applicant's check should not be construed as confirmation of acceptance. Until the applicant receives final written acceptance or denial of exhibit space, any funds expended for the development or construction of an exhibit booth are done so at the applicant's own risk.

The Committee does not guarantee that it will be able to assign the space requested. Previous booth location will be considered but cannot be guaranteed.

In addition, the Committee cannot guarantee that competitors will not be placed near each other, but will endeavor not to do so.

The priority mailing deadline is March 15, 2024. After this date, booths will be allocated on a first-come, first-assigned basis. Previous Exhibitors will receive preference providing their Application/Contract is received prior to March 15.

Assignments of space not rejected in writing by the Exhibitor within 14 days after notification of space assignment will be presumed to be accepted by the Exhibitor.

In order to be included in the Exhibitor Guide classified listing, Exhibitors must submit their product classifications together with the Application/Contract so it can be included on the GNYDM website.

The number of product listings allowed is based on the number of booths rented, and this information is detailed on the classification listing form part of the Application/Contract. Enter correct product codes on the form as these codes are used for data entry in the production of the Program & Exhibit Guide.

2. CHARGES FOR SPACE

EXHIBIT BOOTHS, CONFERENCE ROOMS, EXECUTIVE SUITES, AND DAILY CONFERENCE ROOMS

| BOOTH SIZE | *2024 EARLY BIRD RATES | RATES UNTIL | RATES AFTER |
|-----------------|------------------------|-------------------|-------------|
| | NOV. 29 - JAN. 15 | JAN. 15 - MAR. 15 | MAR. 15 |
| 8x10 | \$4,050.00 | \$4,110.00 | \$4,170.00 |
| 8x10 Corner | \$4,660.00 | \$4,730.00 | \$4,800.00 |
| 10x10 | \$5,065.00 | \$5,140.00 | \$5,215.00 |
| 10x10 Corner | \$5,800.00 | \$5,890.00 | \$5,975.00 |
| 10x15 (2) | \$7,555.00 | \$7,670.00 | \$7,785.00 |
| Extras | | | |
| Conference Room | \$3,630.00 | \$3,685.00 | \$3,740.00 |
| Executive Suite | \$8,995.00 | \$9,130.00 | \$9,300.00 |
| 10x10 DCR | \$1,150.00 | \$1,170.00 | \$1,190.00 |
| 10x20 DCR | \$1,760.00 | \$1,790.00 | \$1,800.00 |
| | *NO INCREASE | | |

Instructions: Submit this Application, with \$1,100.00 deposit per each 10' x 10' booth (NON-REFUNDABLE). Deposits can be made by check, wire transfer or credit card. Final payment is due on or before June 2. Full payment must accompany contracts submitted after June 2. Valid Certificate of Insurance is required. Full payment is required for international companies. The company name, address, city, state/country, customer service phone, fax numbers, E-mail, and Website address as shown on this form are for use in the Program and Exhibit Guide for Applications received Prior to June 15.

The price of the booth includes the following: pipe and drape 8' high (2.5m) in the rear and 36" (91.44cm) on each side; a single-line identification sign with Exhibiting Company name and booth number; 12 Exhibitor badges per 10 x 10 booth and a listing on our website and any publications that might be published.

Exhibitors requesting island space must rent additional space to create an island configuration. For example, if the Exhibitor requests a 20' x 30' island (six booths), a 20' x 40' space (eight booths) will be needed to create the island.

The minimum size for a peninsula booth configuration is 20' x 20'. This policy is due to the limited number of corner booths. Exhibitors requesting a peninsula configuration must adhere to the following policy: no solid exhibition construction will be permitted to exceed 48 inches in height unless it is at least 5' from the nearest aisle. This means that peninsula booths cannot have a 20' back wall. (Only 10')

PAVILIONS

Island space with widths greater than 20' (which includes renting aisle space), may be obtained with written approval of the Committee. In designated areas of the Exhibit Hall aisle space may be rented and become a contiguous part of your Exhibit. Minimum size for Pavilion configuration is 20 x 50. The Exhibitor will have to purchase a 30 x 50 space in order to create a 20 x 50 Pavilion. No blocking of the aisle is permitted.

CONFERENCE ROOMS

Conference rooms are only available to exhibit booth lessees. They are located on the north perimeter of the Exhibit Hall and can be used for a variety of purposes: sales discussions with customers, staff lounges, staff meeting rooms or storage. Assignments are on a first-come basis. All refreshments utilized in conference rooms must be ordered through Cultivate. 10' X 10' conference rooms are available at a cost of \$3,630 each (\$3,685 after January 15th, and \$3,740 after March 15th). Multiple rooms can be combined into a single space. Each conference room has 8 foot high hardwall construction, two door keys, a sign and carpet. Customization, additional lighting, furnishings and upgrade of conference rooms are available through Freeman.

DAILY CONFERENCE ROOMS

Each room includes: hardwall configuration, carpeting, keys, table and chairs.

EXECUTIVE SUITES

Four 11 x 30 suites overlooking the exhibit floor are available for the entire Meeting. Each suite provides the Exhibitor with carpeting, private bathroom and kitchen facilities, conference table and 8 chairs set up. This is an ideal meeting room for busy executives, private meetings with customers and/or a staff lounge. Food service is available through Centerplate.

3. TERMS OF PAYMENT

The Committee requires a deposit of \$1,100.00

for each booth space or conference room with the Application/Contract. The entire balance must be received by the Committee on or before June 2, 2024. An Application/Contract made after June 2, 2024, must be accompanied by full payment. An Application/Contract received after October 29, 2024, must be accompanied by full payment in the form of certified check or cash. In the event that the Exhibitor shall fail to make payment of any balance on or prior to said due date, then and in addition to any and all other rights and remedies thereby available to it, the Committee may, at its option, terminate the contract, retain as liquidated damages any payment made thereunder, and assign the space specified therein to any third party or parties or use the same for such other purposes, if any, as it may deem appropriate, all without notice and without further liability to the Exhibitor. Each payment by the Exhibitor shall be made by check payable to the Greater New York Dental Meeting and such payment shall not be deemed made until the check clears the bank on which it is drawn. Each check and contract shall be delivered to Ms. Carla Borg at the Greater New York Dental Meeting, 200 West 41st Street - Suite 1101, New York, NY 10036-7203. All checks shall be drawn upon and payable in U.S. dollars only at banks located and authorized to transact business in the United States. Third party checks are not accepted. A \$40.00 bank charge must be paid for each overseas bank draft submitted. A charge of \$40.00 will be assessed for any check returned from bank unpaid for any reason.

4. CANCELLATION

If the Exhibitor shall seek to cancel its contract, **all cancellations must be made in writing. Cancellations occurring on or before June 2 will result in refund of the booth balance, less the non-refundable deposit per cancelled booth or meeting room. Cancellations occurring after that date result in 100% of the booth fee being forfeited. Any cancellations on new Application/Contract received after June 2, the booth balance, less the non-refundable deposit, will be refunded if cancelled within 14 days of being assigned booth space. Cancellations made after that time frame will result in 100% of the booth fee being forfeited.** Upon receipt of any such notice of cancellation, the Committee may assign the Exhibitor's space to any third party or parties or use the same for such other purposes as it may deem necessary, all without notice and without further liability to the Exhibitor.

Exhibitors are not entitled to a refund, and the Meeting will not issue a refund, to exhibitors under any circumstances after November 1, 2024.

If the Exhibitor shall seek to cancel a conference room and/or executive suite, written notice is required. If such notice is received by the Committee prior to June 2, 2024, the Ex-

hibitor shall be entitled to a refund of its entire payment. If notice is received after June 2, Exhibitor is entitled to a refund of money paid in excess of \$1,100. After June 3, Exhibitor is not entitled to any refund of monies paid.

5. THE EXHIBITION

The exhibition shall be held at the Jacob K. Javits Convention Center of New York, operated by the New York Convention Center Operating Corporation (the "Center"). The Exhibitor shall be subject to the applicable rules and requirements of the Center, in addition to the obligation to comply with the provisions of the contract with the Committee.

The following shall be the exhibition hours during the Meeting, and the Exhibitor shall keep its exhibit open and on display and properly manned throughout all such hours, but none others:

| | |
|-----------------------|---------------------|
| Sunday, December 1 | 9:30 A.M.-5:30 P.M. |
| Monday, December 2 | 9:30 A.M.-5:30 P.M. |
| Tuesday, December 3 | 9:30 A.M.-5:30 P.M. |
| Wednesday, December 4 | 9:30 A.M.-3:00 P.M. |

Failure of the Exhibitor to comply with the provisions of this Paragraph "5" shall constitute a substantial violation of these Rules and Regulations and of the contract of which it forms a part.

6. SETTING UP EXHIBITS

Subject to the conditions hereinafter stated, exhibit space will be available for the setting up of displays at 10:00 A.M. on Friday, November 29, 2024. The Exhibitor must have all packing cases, crates and containers emptied and labeled and ready for pick up and storage by 10:00 A.M. on Saturday, November 30, 2024, and the entire exhibit, with all displays, must be complete and ready for inspection and exhibition by 5:00 P.M. on Saturday, November 30, 2024. In the event that the Exhibitor shall fail to carry out and complete such setting up within the time and in the manner thus specified, the Committee may, at its option, remove the Exhibitor's property from the exhibition area and store or otherwise dispose of the same in such fashion as it may deem necessary, but at the sole cost and expense of the Exhibitor, and such failure on the Exhibitor's part shall constitute a substantial violation of these Rules and Regulations.

At no time and under no circumstances, shall the Exhibitor keep or store any packing cases, crates or containers or any other packing materials at, under or behind its displays or in or at its exhibit.

7. FAILURE TO OCCUPY SPACE

Any space not claimed and/or occupied one hour after the show opening may be resold or reassigned without refund or credit.

8. JAVITS CENTER SERVICES

The Center has the exclusive right to install and provide telephone, telecommunication, water, waste water, plumbing and electrical services. The Javits Center also has the exclusive right to supply the labor utilized within the Center to perform any of the services described in the Javits Center Work Rules set forth in Paragraph "9" hereof, and neither Exhibitor nor any contractor employed by Exhibitor, nor any vendors supplying goods or services to Exhibitor shall utilize any other labor to perform such services. Such labor shall be provided on written order at the established rates of the Center for such services and shall be utilized pursuant to the Javits Center Work Rules as set forth in Paragraph "9" hereof.

Exhibitor must include the Javits Center Work Rules in any contract or agreement between Exhibitor and any contractor or vendor and Exhibitor must require compliance with said rules by any contractor, vendor and its agents, representatives, employees and subcontractors. Exhibitor is responsible for such compliance, and failure by a contractor, vendor or its agents, representatives, employees or subcontractors to comply with this Paragraph or the Javits Center Work Rules set forth in Paragraph "9" hereof shall be a substantial violation of these Rules and Regulations. The Center has the right to approve all prices charged by any contractor for services described in the Javits Center Work Rules.

With regard to services not mentioned in Paragraph "8" or Paragraph "9" hereof, Exhibitor may contract with persons approved by the Committee and the Center for services not available from the Center.

All work or labor involved in or connected with the loading, unloading and moving Exhibitors' freight materials and machinery must be performed in accordance with the Javits Center Work Rules set forth in Paragraph "9" hereof.

All work or labor involved in or connected with the construction, erection, installation, maintenance or dismantling of exhibits, including, without limitation, all displays, backgrounds, booths, appointments and floor or base coverings, and any and all parts or portions thereof, are and shall be within the jurisdiction of the International Brotherhood of Carpenters and Joiners, New York District Council, which also has and shall have jurisdiction over the uncrating and recrating of all exhibit materials, equipment and other property, and all work or labor requiring the use of bolts, screws or nail fasteners, all work or labor involved in or connected with tying, hanging, nailing or taping of flags, banners, drapes or signs, including but not limited to wall draperies, table skirting, booth equipment draperies, flags, bunting or party decorations, all work or labor involved in

or connected with the laying of tile, carpet or rugs, skidding, reskidding and turntables, all work or labor regarding handling, distributing or delivering of furniture, carpeting, rugs, modular interlocking booth systems, other standardized equipment or other equipment owned or leased by Exhibitor must be performed in accordance with the Javits Center Work Rules set forth in Paragraph "9" hereof.

Notwithstanding the Javits Center Work Rules, hand-carry items can be brought into the Center through the front of the building (eastside - 11th Avenue only), as long as parking regulations are obeyed. Parking locations will be assigned by the Event Manager. Parking is limited to vehicles no larger than a Ford Econoline van. Vehicles must be attended by a licensed driver at all times. Exhibitors may use nothing larger than a two-wheeled baggage cart (plastic or rubber wheels only) to move their items.

Notwithstanding the Javits Center Work Rules, "Pop-up" displays equal or less than 10 feet in length, capable of being carried by hand by one person may be brought into the Center. Exhibitors moving items must use doors and routes designated by the Event Manager. Individuals moving these items must be employees of Exhibitor and must carry identification and be wearing either an Exhibitor or installation badge to verify that fact.

Exhibitors may unpack, pack and arrange their merchandise and products in their exhibit. Exhibitors may install or dismantle their exhibit and lay carpet in their exhibit as long as the booth size is 100 square feet or less and the work can be done without tools. Those performing the work must be employees of the Exhibitor and must carry identification and be wearing either an Exhibitor or installation badge to verify that fact.

Advance arrangements for all such union work or Center labor shall be made by the Exhibitor with the Official Full Service Contractor,
GREATER NEW YORK DENTAL MEETING
Exhibiting Company Name, Booth # _____,
C/O Freeman, 140 Central Avenue, Kearny, NJ 07032, and if further information should be sought as to such union work or Center labor, the Exhibitor may telephone said firm at (201) 299-7575.

9. JAVITS CENTER WORK RULES

Contractor and Exhibitor must hire Javits Center labor to perform the following tasks:

- (a) Loading, unloading and moving Exhibitor freight materials and machinery, loading and unloading decorating contractors' equipment to and from a marshalling point on the exhibit show floor, but Exhibitor hand-carry items are exempted from this requirement. **No 4-wheeled carts permitted.**
- (b) Crating and re-crating, and all work involved

in the erection and dismantling of exhibits, displays, backgrounds and booths; all work requiring the use of bolts and screws or nail fasteners; tying, hanging or nailing, taping of flags, banners, signs, tile and rug-laying, skidding and reskidding and turntables; handling and delivery of furniture, carpeting, modular interlocking booth systems and other contractor owned and leased equipment; pad wrapping, protection work, ramp protection; and installing draperies, including but not limited to wall draperies, table skirting, booth equipment draperies, flag and bunting and party decorations, but "Pop-up" booths are exempted from this requirement.

Contractors are permitted to use their own personnel as managers and supervisors of the labor described above, provided that they have completed a questionnaire and have been approved by the Center, that they are performing only legitimate managerial tasks, and that the company maintains a reasonable ratio of managers and supervisors to labor. Violation of any of these conditions shall result in a revocation not only of the supervising employee's authorization, but also of the contractor's authorization to conduct business at the Center.

Employees of the Center, contractors, employees of contractors, Exhibitors and employees of Exhibitors are prohibited from giving to or accepting from anyone, directly or indirectly, any gratuities or anything else for any reason in the Center or in relation to any work performed in the Center.

10. USE OF EXHIBITOR APPOINTED CONTRACTOR

If an Exhibitor plans to use a contractor other than Freeman for installation and dismantling of its exhibit, they must complete an Exhibitor Appointed Contractor form. Notice of this intent must be sent to the Greater New York Dental Meeting and Freeman by August 25, 2024. Exhibitors who have not sent notification by this date must use the Official Full Service Contractor. The Contractor, and any of its employees or agents must comply with the Javits Center Work Rules set forth in Paragraph "9" hereof. In addition, the selected Contractor must complete a "Javits Center questionnaire" and provide the Greater New York Dental Meeting with the following: a copy of its license to operate in the State of New York and the Jacob K. Javits Convention Center, a list of all personnel to be conducting services for the Exhibitor, and an original certificate of insurance listing the Greater New York Dental Meeting, the New York Convention Center Operating Corporation, the State of New York, the New York Convention Center Development Corporation, the Empire State Development Corporation, the Triborough Bridge and Tunnel Authority and Freeman and its employees as additional named insureds, as set forth in the indemnification and insurance provisions in the contract for exhibit space. The Exhibi-

tor is responsible for supplying the appointed Contractor with the necessary information included in the exhibit packet. The employees of the Appointed Contractor must report to the registration area to pick up their badges prior to commencing work. The Exhibitor assumes liability for the Exhibitor Appointed Contractor and his employees. Solicitation for business by any Exhibitor Appointed Contractor on the exhibit floor is expressly forbidden. Any Exhibitor Appointed Contractor not meeting the above requirements and deadline will not be allowed to erect or dismantle said exhibits.

11. DISMANTLING OF EXHIBITS

Exhibit Hall 3A Exhibitors must be packed by 11:00 A.M. Thursday, December 5, 2024 to facilitate moving out by 9:00 P.M. that evening. All transportation arrangements for these Exhibitors must be made with Freeman Company by 4:00 P.M. on December 5, 2024 or will be subject to re-routing. (Subject to change)

Exhibit Halls 3E, 3B and 3D must be packed by 9:00 P.M. Thursday, December 5, 2024 and transportation arrangements must be made by 10:00 A.M. Friday, December 6, 2024. Please contact Exhibits Manager or the Official Full Service Contractor for more details. (Subject to change)

Since the Official Full Service Contractor for the Meeting will, beginning at 5:00 P.M. on Wednesday, December 4, 2024, arrange with Javits Center labor to remove all aisle carpeting and to return from storage to the Exhibitor's booth for packing its cases, crates and containers, the Exhibitor shall arrange with the Official Full Service Contractor or their Exhibitor Appointed Contractor for Javits Center labor, at its expense, to dismantle and pack its entire exhibit and all displays and materials included therein and shall arrange to have the Official Full Service Contractor using Convention Center labor remove the same, together with any and all other property belonging to the Exhibitor or for which it is responsible, from the Center.

If the Exhibitor uses an automobile, station wagon, small van or like vehicle for such removal, it may do so on Wednesday evening, December 4, 2024, by checking into the freight service desk starting at 4:00 P.M. and by packing its entire exhibit, with all its displays, materials and other property, in such vehicle.

Such removal shall be accomplished between 5:30 P.M. and 9:30 P.M. that day, namely, Wednesday, December 4, 2024, in the same order in which the check-in took place. During those hours the Official Full Service Contractor will withhold the loading of trucks, and will not commence such loading until about 8:00 A.M. on Thursday, December 5, 2024.

In the event that the Exhibitor shall fail to effect removal of all its property within the time and in the manner specified above, such re-

removal may be effected by the Committee or its designee, and the Exhibitor's property may be stored or otherwise disposed of by such means, at such times and under such circumstances as the Committee may deem appropriate, but at the sole cost and expense of the Exhibitor. The Exhibitor releases the Committee or its designee from any claim for damages resulting from such storage or disposal.

12. EXHIBIT LIMITATIONS

All exhibits must be constructed and set to the rear of the booth space. No exhibit can be set forward as to block, cover or screen any other exhibit. In addition, the Exhibitor shall conform to and comply with the following requirements in the installation, maintenance and display of its exhibit. It is required that plans for all island/peninsula exhibits be submitted to the Greater New York Dental Meeting for review/approval at least 90 days prior to Meeting dates. If not received, exhibitor will be responsible for any onsite charges for changes required that do not adhere to the regulations of the Meeting:

(a) No exhibit shall cover, screen or obscure any exit or other signs, or interfere with access to exits, fire-fighting equipment, first aid facilities or emergency or other equipment;

(b) No exhibit shall be permitted to obstruct or otherwise interfere with any part of the exhibition area, or passage to washrooms, checkrooms, exits or concession locations, or obscure, cover or screen, either in whole or in part, any other exhibit or exhibits, or any washrooms, checkrooms, exits or concession locations;

(c) The Exhibitor shall provide either a suitable background or booth for its exhibit, with all framework and exposed surfaces thereof properly covered and decorated, and with all background placements located solely along the solid lines shown on the Floor Plan, and not elsewhere. All booths must be carpeted at the Exhibitors' expense;

(d) No background, sign, decoration or other material or installation shall exceed (28) feet in height at any point or place, except in exhibit spaces, numbered, 1900 through 2400 where the height may not exceed fourteen (14) feet; and no side or dividing partition or other separator between exhibits shall extend higher than forty-eight (48) inches above floor level; five feet from aisle; (see diagram); and any sign or display that extends higher than the (8) foot background curtain may not have copy or design facing in the direction of other companies. The rear of the sign/display must be suitably finished or draped. Double-sided or rotating signs are only allowed for those Exhibitors who have an island or peninsula configuration within the confines of their booth. If a close-out is deemed necessary by the Committee, it becomes the responsibility of the Exhibitor to order it from the Contractor;

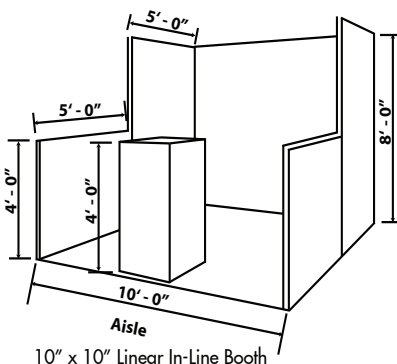

10' x 10' Linear In-Line Booth

(e) Attachment to Exhibit Hall ceiling beams or truss is permitted only through the Official Full Service Contractor, Freeman. Requests for written approval of hanging signs truss and banners must be submitted to the Exhibits Committee by July 6, 2024, and to Freeman 60 days before installation. The request must include a description or drawing of the sign, truss or banner, proposed method of installation, location of hanging points, and total weight. All hanging signs, truss and banners must be set back at least 25% of the booth's width dimension from the back line of the booth. Hanging signs and graphics will not be permitted to a total length which exceeds 50% of the corresponding dimension of your booth. Please note that no signs, truss or banners may be hung without prior written approval from show management. Should there be any discrepancy between what the Committee approved and what is actually hung on-site, the sign will be removed at the Exhibitor's expense; Hanging signs cannot exceed 28' for maximum height or be lower than 16' of said sign.

Island/Peninsula Configuration

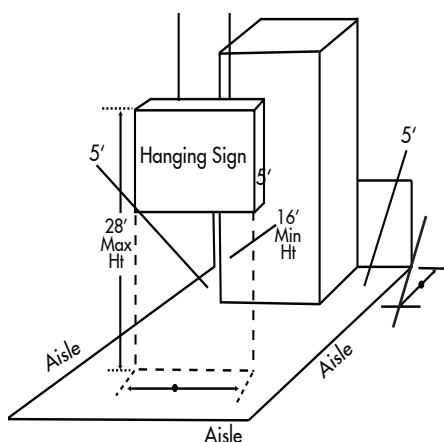

Length of sign not to exceed 50% of the corresponding dimension of the booth.

Set back at least 25% of the booths width dimension from the back line of the booth.

(f) Any awning, topping, covering or other projection or installation over the exhibit or extending forward from the face of the back or background of the exhibit shall not exceed sixty (60) inches in length or depth so long as such extension is 5 feet from the aisle and shall not, to any extent, obstruct, block or interfere

with light or lighting for, or full use or visibility of, the space of any other Exhibitor;

(g) No Duplex exhibit shall be permitted without the written consent of the Committee with a 60 day notification, and no Exhibit, nor any part thereof, shall extend or project beyond the space assigned to the Exhibitor, and all of the Exhibitor's activities shall be conducted and carried on, and its representatives shall function and operate, solely within the confines of said space;

(h) No Exhibitor shall install, maintain, operate or use any public address or other sound system whatever or any loudspeaker of any kind without written permission of the Committee. Sound must be limited to the confines of the booth at a volume not to disturb or disrupt the activities of neighboring Exhibitors. Speakers and other sound devices should be positioned so as to direct sound into the booth rather than into the aisle. The Committee retains the right to determine acceptable levels of sound.

(i) No Exhibitor shall install, maintain, operate or use any light, lighting or other contrivance, device or equipment of any type, which in the judgement of the Committee, may be a source of interference or inconvenience to any other Exhibitor or to the Exhibition. Blinking lights and rotating signage are only permitted with the prior written approval of the Committee.

(j) The Exhibitor shall, throughout the exhibition, keep and maintain its exhibit and all parts thereof in clean, dust free and otherwise orderly condition, with all literature, so called "hand-outs" and similar written or printed materials kept in neat and trim fashion, and any needful reserve quantities thereof properly stored in closed containers within the exhibit space. In the event that the Exhibitor shall cause or create any excessive litter or waste, the same will be removed by the Center's Building Service Department at the expense of the Exhibitor;

(k) The Exhibitor shall not: (1) make any material change in its exhibit or the displays therein after the initial installation thereof; (2) fail to keep its exhibit open, operating and adequately manned during the stated exhibition hours; or (3) discontinue, close or remove its exhibit, either in whole or in part, until the conclusion of the entire exhibition, unless otherwise directed or authorized by the Committee;

(l) The Committee shall be the sole judge as to acceptability of exhibits. An exhibit may not display any product or distribute advertisements for any product that infringes on the registered trademark, copyright or patent of another company. All exhibits shall conform to and comply with: all requirements of both the Committee and the Center;

(m) Gasoline powered vehicles used for exhibit or display will be allowed to operate in the Center only during move-in and move-out periods, and when on display shall be subject to the following restrictions: (1) no more than one gallon

of fuel shall be kept in the tank of any vehicle; (2) no tank shall be re-fueled or emptied within the confines of the Center; (3) every tank shall be equipped with a key-lock gasoline cap; (4) all battery cables must be disconnected and the ends taped; (5) each vehicle must be locked during non-exhibit hours; (6) a tagged set of keys to each vehicle must be delivered to the Center's Security Office immediately upon entry of the vehicle into the Center; (7) no repairs or alterations to any vehicle shall be made in or at the Center; (8) adequate and suitable fire extinguishers and fire prevention equipment shall be provided by the Exhibitor and kept in close proximity to each vehicle; and (9) a protective sheet of visqueen, tarpaulin or comparable material shall be placed and kept under all vehicles and other movable equipment and devices in all areas within the Center in which such vehicles, equipment or devices are operating or being operated; (10) spotting FEE: Exhibitors with mobile or motorized equipment will require guidance to their respective booth(s). This guidance is required and provided by Freeman to prevent damage that may occur to exhibits, or property of others, or when necessary to move crates that may be in the aisles. Exhibitors may drive their motorized equipment in and out of the exhibit areas or Freeman will supply an operator when available.

13. COMPLIANCE WITH LAW AND OTHER REQUIREMENTS

Exhibitor will obtain, at its expense, any permits required for the exhibit and shall provide the Center and the Committee with copies of said permits prior to August 25, 2024.

Exhibitor shall not use or permit the exhibit space to be used:

- (a) in conflict with any law, ordinances, rule or regulation of any governmental authority;
- (b) in any manner which could violate the Exhibitor's insurance or increase the rate of the Committee's or the Center's insurance;
- (c) in any manner which constitutes waste or nuisance;
- (d) in any manner which causes injury to the Center, alteration to the Center; or
- (e) in violation of the Center's Rules and Regulations, including without limitation the Javits Center Work Rules, as such may exist from time to time.

Exhibitors who want to sponsor any type of contest, raffle or drawing for prizes must obtain written permission from the Exhibits Committee. The following rules must be adhered to:

- (a) the Exhibitor must comply with all local, state and federal laws that apply to such raffles, contests or drawings;

- (b) contests, raffle or drawing rules must be posted at the booth. The rules must include: eligibility; date and time of drawing (contest, raffle); the words "no purchase necessary to enter"; odds of winning; how winners will be notified; how participants can find out who won; etc;

- (c) the Exhibitor must complete a form which will be supplied and agree to indemnify the Greater New York Dental Meeting in the event of any claims arising from the operation of the raffle or contest;

- (d) The Greater New York Dental Meeting must be notified of the name(s) of the winner(s) when the prize(s) have been awarded.

No Exhibitor shall construct, install, maintain or use as part of or in connection with its exhibit or the displays therein any material, equipment or other item or thing which does not comply with the Life Safety Code, with all requirements of the Fire Department of The City of New York, the Department of Buildings of The City of New York, the Bureau of Gas and Electricity of the Department of General Services of The City of New York, the Division of Water Resources of the Department of Environmental Protection of The City of New York and the New York Board of Fire Underwriters, and with all other laws and requirements of the Federal, State, County and City departments, agencies, officials and authorities having jurisdiction in the premises.

Without limiting the foregoing provisions of this Paragraph "13", compliance is also required with the following:

- (a) Only such open flames as are essential to an exhibit and for which a Fire Department permit has been issued shall be allowed in or at the Center, and then only at such times, under such conditions and with such precautions as the Committee and the Center shall specify;
- (b) No explosives, fuel, combustible or hazardous material, decorative material not fireproofed or any materials or substances deemed hazardous by the Fire Department of The City of New York may be brought into the Center;
- (c) All curtains, draperies, carpets, fabrics, plastics and decorative and other items and materials to be included in or made part of any exhibit shall, at the Exhibitor's expense and prior to the delivery, installation or use thereof in or at the Center or the exhibit, be fireproofed or flameproofed by methods or means approved by the Fire Department of The City of New York, and the Exhibitor shall furnish, in advance, a notarized statement or certificate attesting to such fireproofing or flameproofing;
- (d) No oilcloth, tarpaper, plastics, synthetics or other materials of any kind which cannot

or may not be effectively fireproofed or flameproofed shall be delivered, installed or used in or at any exhibit; and

- (e) The Exhibitor shall, at its expense, permit and arrange for any such flame test or tests as the Committee, the Center or the Fire Department of The City of New York may request or require.

- (f) any company demonstrating laser equipment on the exhibit floor must have a certified compliance officer in attendance.

14. ASSIGNMENT SUBLETTING OR SHARING

The Exhibitor shall use its space solely and exclusively for the exhibition of the materials, equipment or services normally manufactured, distributed or furnished by it in the regular course of its business, and for no other items or purposes of any kind.

The Exhibitor shall not assign, sublet, license or otherwise release, transfer, apportion or dispose of its exhibit space or any part thereof, and any use of all or any part of said space by or for any person, firm or entity other than the Exhibitor, upon any terms whatever, is expressly prohibited.

Each space may be used only by a single business entity and no sharing of space will be permitted.

15. EXHIBITS OR EDUCATIONAL PROGRAMS IN OTHER AREAS

The Exhibitor shall, during the Meeting period from Friday, November 29, 2024, through Wednesday, December 4, 2024, use or employ for exhibit or display purposes, or for the conduct of seminars, clinics, promotions, or for the distribution of samples, literature or like items, or for any similar or related activities involved in or connected with its business or business affairs or operations, only the exhibit space for which it has contracted with the Committee, and shall not, during that period, use or attempt to use, for any such purposes, whether directly or indirectly, any other area in the Center, or any exhibit, display or other space of any type in any hotel, hall, room or other quarters or facilities of any kind located within The City of New York without the written approval of the Committee. Any failure or refusal of the Exhibitor to comply with or conform to the provisions of this Paragraph "15" shall constitute a substantial violation of these Rules and Regulations.

Evening social functions that incorporate any educational component including lecture, seminar, clinic and/or product demonstration, shall be permitted in appropriate forums.

16. NEW PRODUCT AND TECHNOLOGY PAVILION

Exhibitors can display their newest products and/or services free of charge at the New Product and Technology, centrally located for prime visibility.

17. CARE OF THE CENTER

The Exhibitor shall be responsible for all damage to the Center, its structures, furnishings, facilities, equipment and appurtenances, caused or contributed to by the Exhibitor, its agents, employees, representatives, guests or visitors, irrespective of whether such damage shall be attributable to any negligence on the part of the Exhibitor; and the Exhibitor shall promptly pay for such damage and for all costs and expenses on account thereof, and shall indemnify, keep and hold harmless and defend the Committee from and against the same. In addition:

(a) The Exhibitor shall not: (1) mark or paint on, drill, screw or cut into, place hooks or tacks, or in any manner injure, mar, deface or alter or otherwise change any walls, columns, partitions, floors, escalators, doors, signs or other aspects or parts of the Center, its structures, furnishings, facilities, equipment or appurtenances; (2) tape, hang, paste, tack, nail, wire, screw or otherwise affix, attach, append or otherwise connect any signs, bills, self adhesive stickers, badges, banners, decorations, displays, advertisements or other articles, materials, items or things to walls, columns, partitions, floors, escalators, doors, signs or other aspects or parts of the Center, its said structures, furnishings, facilities, equipment or appurtenances; or (3) remove any ceiling or floor tiles or wall plates; (4) lay any carpet over Center carpets; or (5) remove, disable, disconnect, detach, impair or otherwise interfere with any of the Center's automatic door closing devices or equipment, or prop open or otherwise keep open any of the Center's doors or other accesses;

(b) At no time shall the Exhibitor bring into, store or keep in or at the Center any gasoline, kerosene, acetylene, helium or other fuel or volatile or inflammable liquids or gases, or any fireworks, flash pots (whether empty or filled), explosives, combustibles or other hazardous substances, materials, fluids or gases except as otherwise provided in Paragraph "12" hereof, and except such as shall be permitted by law and the authorities having jurisdiction thereof, and then only at such times, under such conditions and with such precautions as the Committee and the Center shall specify;

(c) The Exhibitor shall not pour grease, contaminated material or any other waste materials into the Center's drains, and shall use for such purpose only the metal containers that will be

made available, at the Exhibitor's request, by the Center's Building Service Department;

(d) The Exhibitor shall not use in either its exhibit space or in any other area of the Center: any so-called "glitter" or like materials; or any so-called "stick-ons" or other adhesive decals, badges, velcro or similar items of any kind;

(e) The Exhibitor shall exercise the utmost care and caution in the use of lamps, lights and other electrical equipment and devices included in its exhibit, and, at all such times as its exhibit may be unmanned or unattended, all electricity and electrical current for said equipment and devices shall be effectively shut off and secured; and

(f) The Exhibitor shall not bring into the Center or keep or use in its exhibit any electrical or related or other equipment or devices which have not been officially approved by the Underwriters Laboratories.

18. ELECTRICAL AND OTHER CONNECTIONS

No wiring, installations or connections for any utility or other services or facilities, including, but not limited to, electrical, video, audio, water, compressed air and other equipment and accommodations, shall be made or effected by or for the Exhibitor without the prior written consent of the Committee and the Center and, if such consent is granted, then such wiring, installations and connections shall be made at the sole cost and expense of the Exhibitor, in such manner and by such means as the Center may require, by such contractors as shall be designated by the Center, and under the supervision of the Center's Building Service Department. The Exhibitor shall pay directly to the Center, promptly upon receipt of bills or invoices therefor, all charges for such wiring, installations and connections and for the operation and use of the same, as well as for the costs and expenses to be incurred for the removal thereof. The Center may require of the Exhibitor advance deposits or payments for all such charges.

At least four (4) months prior to the commencement of the Meeting, the Exhibitor shall advise the Committee in writing of the wiring, installations and connections it seeks for use at said Meeting and, in the absence of receipt of such advice, either the Committee or the Center may thereafter refuse or deem itself unable to grant or consider granting consent for the same.

There will be available through existing facilities at the Center alternating (AC) electric current of 110 volt, 60 amp, single phase, or 208 volt, 60 amp, single or three phase, or 460 volt. If the Exhibitor anticipates a need for other or different electric current for its exhibit, written notice thereof, within the above mentioned

period of four (4) months, shall be given by the Exhibitor to both the Committee and the Center, but no assurance is given that such other or different electric current can or will be provided or that consent thereto will be granted by the Center or the Committee.

Exhibitors may plug in their own electrical devices and equipment for properly ordered 110 volt electrical service of 1500 watts or less. All plugs must be U-ground 3-prong plugs.

19. ELECTRICAL SIGNS AND DEVICES

No flickering, strobe, flashing, blinking, changing, rotating, laser lights or similar sign, sign-board or equipment may be installed or used by the Exhibitor without written permission of the Committee under any circumstances whatever, and no other electrical sign, device or equipment of any type shall be installed or used by the Exhibitor without the prior written consent of the Committee and the Center.

All decorative fountains must be waterproof and must be pre-tested and approved by the Center's Building and Service Department prior to installation.

Any electrical connections, light, truss, etc., must remain within the designated space, unless written permission is given by the GNYDM Committee.

In the event that, due to fire or other casualty, strikes, lockouts or labor difficulties, construction operations, severe weather conditions, explosions, sabotage, accident, riot, civil commotion, terrorism, act of war or any action or condition of the Center, or any litigation, action of the elements, act of God, governmental restrictions, legal requirements or other circumstances beyond the Committee's control, the Meeting is not held, the exhibition is barred, prevented or cancelled, or the Exhibitor's space is wholly unavailable for its use (for reasons other than any breach or default on the part of the Exhibitor) then and in any of such events the sole obligation of the Committee shall be to refund to the Exhibitor prorated daily sums theretofore paid to the Committee under the Exhibitor's contract, and both parties shall thereupon be deemed released of and from all further liability under said contract.

20. CIRCUMSTANCES BEYOND CONTROL

In the event that, due to any of the aforesaid events, occurrences, contingencies or circumstances, the exhibition shall terminate or be discontinued, or the Exhibitor shall be deprived of its space (for reasons other than its own breach or default), after the commencement of the exhibition but prior to the scheduled conclusion thereof as hereinbefore specified, then the contract charge for the Exhibitor's said space shall be apportioned appropriately,

the Committee shall refund to the Exhibitor the pro rata portion of said contract charge applicable to the unused period of the exhibition, and both parties shall thereupon be deemed released of and from all further liability under said contract.

21. SECURITY

Although the Committee intends to adopt certain security measures for the Meeting, the same shall not be deemed nor constitute, in any respect or to any extent, the assumption by the Committee or the Center of any liability or responsibility for the safety or security of the Exhibitor, its agents, employees, representatives, guests or visitors or its exhibit, displays or other property. There shall be no bailor and bailee relationship between the Committee or the Center and the Exhibitors, or any person described above. Exhibitor will promptly notify the Committee and the Center, in writing of any incident or loss or damage to the property of Exhibitor or invitees occurring within the premises during the Meeting.

The Exhibitor is therefor urged to take all such steps, measures and precautions as may be necessary to protect itself, its agents, employees, representatives, guests and visitors, as well as its exhibit, displays and other property, against all possible injury, damage, loss and destruction during the Meeting, including without limitation, loss or damage occasioned by theft, fire, act of God or other insurable casualty, and if the Exhibitor shall seek or require any special safeguards or any extra security, it shall make arrangements therefor, in advance of the commencement of the Meeting, with the Security Contractor for the Meeting.

22. LIABILITY

Exhibitor is fully responsible for all acts or omissions of its contractors and vendors. Exhibitor will ensure that such persons comply with Javits Center Work Rules set forth in Paragraph "9" hereof and will be responsible for any substantial non-compliance by such persons.

There shall be no liability or responsibility on the part of the Committee, the Center, the Security Contractor for the Meeting, or the Official Full Service Contractor for the Meeting, or any of their respective agents, employees and representatives, for any injury or damage to the Exhibitor, its agents, employees, representatives, guests or visitors, or for any loss, damage or destruction of any property belonging to the Exhibitor or used in or in connection with its exhibit or the displays therein. This shall apply irrespective of the manner in which or the circumstances under which any such injury, damage, loss or destruction may occur, and irrespective of whether the same may arise out of any negligence or claimed negligence on the part of the Committee, the Center, the Security Contractor or the Full Service Contractor.

All claims and causes of action therefor shall be, and be deemed to be waived, released and discharged for all purposes.

The Exhibitor shall indemnify, keep and hold safe and harmless and defend the Committee, the Center, the State of New York, the New York Convention Center Development Corporation, the Empire State Development Corporation, the Triborough Bridge and Tunnel Authority, the Security Contractor, and the Official Full Service Contractor and their respective boards of directors, officers, agents, and employees and each of them ("Indemnities") from all claims, losses, liability, damages, actions and judgments arising in, at, out of or in connection with the Exhibitor's exhibit or the installation, maintenance, conduct, use, operation or removal of said exhibit or any part or parts thereof. This includes without limitation, any and all such claims, losses, damages and judgments which may arise out of, be attributable to or in any manner or to any extent involve any negligence or claimed negligence on the part of the Committee, the Center, the Security Contractor or the Official Full Service Contractor.

On or before August 25, 2024, the Exhibitor agrees to provide the Committee with an original certificate of insurance issued by an insurance carrier authorized to do business in The State of New York, evidencing the following insurance coverage in support of the Exhibitor's aforesaid agreement to indemnify, keep and hold safe and harmless and defend. In addition to the Exhibitor, such certificate of insurance shall name as additional insureds the Indemnities.

- (a) General Liability-\$1,000,000 per occurrence/ \$2,000,000 aggregate
- (b) Workmen's Compensation covering employers liability as well as Workers Compensation for the employees:
 - Bodily injury by accident: \$100,000 each accident
 - Bodily injury by disease: \$500,000 policy limit
 - Bodily injury by disease: \$100,000 each employee.
- (c) Automobile-\$500,000 per occurrence combined single limit.
- (d) Excess Liability-\$3,000,000.

All insurance coverage shall also contain a "waiver of subrogation" endorsement and shall provide that the Greater New York Dental Meeting be given at least 30 days notice prior to any termination, cancellation or material change in insurance coverage.

Please note: Facsimiles or photocopies of the Certificate of Insurance are not accepted. Only

original Certificates will satisfy this request.

Failure to comply with this regulation may jeopardize your ability to exhibit at the Greater New York Dental Meeting.

23. SHIPMENTS AND CONSIGNMENTS

All exhibit materials and equipment shipped by or on behalf of the Exhibitor for delivery at the Center prior to 8:00 A.M., Friday, November 29, 2024, must be consigned to the Official Full Service Contractor for the Meeting, to wit,

GREATER NEW YORK DENTAL MEETING
Exhibiting Company Name, Booth # _____,
C/O Freeman, 140 Central Avenue, Kearny, NJ 07032, and, if further information should be sought as to any such consignment, the Exhibitor may telephone the Official Full Service Contractor at (201) 299-7575. No shipment of any materials or equipment will be accepted at the Center in advance of Friday, November 29, 2024.

Any shipments made by or on behalf of the Exhibitor for delivery at the Center on or after November 29, 2024, shall be consigned to the Exhibitor in care of the Meeting at the Center.

All shipments by or for the Exhibitor, irrespective of when made, must be on a prepaid basis and clearly marked with the Exhibitor's space number at the exhibition. All deliveries of such shipments will terminate at the Center's loading dock area, and all pick ups of such shipments are to be made at said loading dock area. The handling of such shipments and the transfer of the same to and from the Exhibitor's space at the exhibition will be performed, at the Exhibitor's expense, by Javits Center labor employed or engaged by the Official Full Service Contractor for such purposes. All deliveries intended to be made by the Exhibitor directly to the Center must first be checked in at the Center's Traffic Control location at West 39th Street and 12th Avenue, New York, New York, (Big Blue Trailer) and all papers for those deliveries must immediately be turned over to the Office of the Traffic Control Supervisor in said Big Blue Trailer. Such deliveries will be received ONLY on Friday and Saturday, November 29 and 30, 2024, both of which dates are overtime days for the Official Full Service Contractor and overtime rates will therefor apply. To avoid such overtime expense, the Exhibitor may, instead, ship in advance to Freeman's Warehouse. All deliveries received at the Warehouse from Wednesday, October 23, 2024, through Friday, November 15, 2024, will be forwarded to the Center on Friday, November 29, 2024, beginning at 8:00 A.M., and overtime rates will be applicable to all such deliveries. There will be no extra charge for the storage of exhibit materials or equipment at the Warehouse since such charge is included in the advance receiving rate. FedEx and UPS do not deliver to the Javits Center on Friday and Saturday, November 29-30, 2024.

During the setting-up and dismantling of exhibits, or the moving in or out of the same as specified in Paragraphs “6” through “11” hereof, as well as during the exhibition itself, no sidewalk deliveries or pick ups will be permitted under any conditions whatever, and no exhibit materials or equipment of any kind, other than such as can properly be hand-carried, shall be taken, moved or transported on any escalators or passenger elevators in the Center.

All hand-carried materials or equipment shall be of such size and quantity as may readily be carried through revolving doors without impairment or interruption of normal operation and use of such doors.

Any use of hand trucks, dollies or flats is prohibited, but Exhibitors may use hand luggage with integral wheels, sample cases or folding baggage carts which comply with the requirements stated above for hand-carried materials or equipment.

There shall be no liability or responsibility whatever on the part of the Committee, the Center, the Security Contractor or the Official Full Service Contractor for any loss, damage or destruction of any of the materials, equipment or other property shipped by or for the Exhibitor, irrespective of whether the same be consigned to or picked up by or for the Committee, the Center, the Exhibitor, the Security Contractor or the Official Full Service Contractor, or any other person or party.

In the event of any labor or related dispute, whether jurisdictional or otherwise, or in the event of any other problem or difficulty involved in or connected with any shipment, consignment or pick up by or for the Exhibitor, then the Committee or the Center may reject, accept, move, delay, immobilize or otherwise deal with any such shipment, consignment or pick up of any or all of the Exhibitor’s materials, equipment and other property included therein, in any such manner and by any such means as the Committee or the Center may deem necessary in the circumstances, and without any liability therefor to the Exhibitor.

24. RESTRICTIONS AND REQUIREMENTS

The Committee shall have and expressly reserves, the right to conduct, carry on, maintain, regulate and operate the exhibition in such manner and by such means as it, in its sole discretion, deems advisable or proper.

The Committee shall have the further right to prohibit, bar, prevent and remove any exhibit or proposed exhibit, or any part or portion thereof, which in the judgment of the Committee is unsuitable or inappropriate for the exhibition or is not in keeping with the character, standards or purposes of the exhibition. Such right shall extend, but shall not be limited, to all materials, equipment, displays, installations and other items or things included in, constituting part of, or used or referred to in or in

connection with any such exhibit.

The Committee shall also have full right and authority to relocate Exhibitors and to alter or revise the floor plan for any cause or reason that the Committee, in its judgment, may deem necessary or advisable.

The Committee shall have the right to bar, eject and remove from the exhibition and the area in which the same is conducted any and all persons whom it may deem disorderly or objectionable or who fail or refuse to comply with any of these Rules and Regulations.

Smoking or carrying a lighted cigar, cigarette or pipe in any exhibition area or in any other room or area used by or reserved for the Meeting is strictly forbidden. The distribution of balloons, push or pulled wheeled baggage and any and all other similar promotional items are prohibited.

The movement of palletized freight using a pallet jack is prohibited on all carpets, unless the Committee and the Center grant their permission, in which case the carpet must be protected with plywood or masonite.

No alcoholic beverages of any nature shall be brought into the Center and no animals or pets shall be allowed in the Center except such as constitute part of an approved exhibit or are seeing-eye dogs.

No wheelchairs, carriages or similar or related equipment or devices are permitted on escalators.

The Center has the right to operate all concessions at the Center, and Exhibitor shall not sell or dispense any concessions or samples in the Center without the prior written approval of the Committee and the Center, except Exhibitor may, however, take orders for services or merchandise which are the subject of the Meeting and distribute samples incident to a particular exhibit at the Meeting, **and then only within the confines of its exhibit**, and provided that no charge is made for the same. Distribution must be done in a dignified manner, must not create a nuisance nor interfere with adjoining exhibits. Should a nuisance or traffic problem due to the distribution of product, samples or souvenirs occur, the Exhibitor will be required to halt distribution, or to distribute the item only at certain times. However, and apart from such samples or souvenirs, no delivery or transfer of goods or other items shall, under any circumstances, be made in any exhibition area, and no payment for any such goods or other items, whether in cash, by check or credit card, or in any other form, shall be made, processed or accepted in said area.

Except in designated locations such as Pavilions, all aisles must at all times remain open and unobstructed, and any use of any aisle for an exhibit, display, demonstration, solicitation of business, distribution of materials, or any other

purpose, except free passage through the exhibition area, is expressly prohibited. Any violation of this rule by an Exhibitor will be deemed a substantial breach of its contract with the Committee and its obligations to the Center.

Any exhibit, display, demonstration, solicitation of business, distribution of materials or other advertising, publicity, canvassing or similar or related activities at the exhibition by, for or on behalf of any person, firm or entity other than the Exhibitor is forbidden.

Exhibitor personnel may not enter, photograph or videotape the exhibit space of another Exhibitor without permission of the latter. Promotional literature and booth copy may cite in footnotes references from dental and other scientific literature, provided the reference is truthful and is a fair and accurate representation of the body of literature supporting the claim. Unwarranted disparagement or unfair comparisons of a competitor’s products or services is not allowed.

Firms and representatives not assigned exhibit space are prohibited from soliciting business in any form in the exhibition hall in the Javits Convention Center. Violators of this prohibition will be required to leave the building. Grey market product sales without manufacturer’s approval is prohibited.

Copyrighted music can only be used on the Exhibit Floor with written permission from the Committee after submission of proof of licensing agreement between the Exhibitor and licensing agencies. Exhibitors should be aware that music played in their booths, whether live or recorded, may be subject to laws governing the use of copyrighted compositions. Exhibitor is solely responsible for any fines or charges incurred by the Meeting for the use of the Exhibitor’s music.

“Live” demonstrations or treatment on patients are not permitted in the Exhibit Hall under any circumstances.

The Greater New York Dental Meeting has adopted the following policy for Laser Company Exhibitors in the exhibition area:

- (a) Lasers must be operated by trained authorized personnel acting under a senior compliance officer who must be present on-site;
- (b) Adequate warning signage of laser usage with the appropriate wavelength being used must be posted;
- (c) Safety glasses of the proper density and wavelength must be worn by all attendees in the demonstration area;
- (d) Water availability and adequate and suitable fire extinguishers must be in near proximity of the laser;

(e) Demonstrative enclosures with proper density and wavelength observation areas must be utilized;

(f) Combustible and explosive material must be removed from the laser demonstration area prior to usage;

(g) All coverings in the Javits Center must be fire retardant, which includes coverings utilized in the area near the laser;

(h) Beam and reflection protection modalities must be utilized;

(i) Proper electrical and lighting installation must be maintained;

(j) No laser equipment may be left unattended in operable condition at any time and a staff member must always be present at the booth during the show hours;

(k) IMPORTANT NOTE: A description of each piece of laser equipment and their safety features must be submitted to the Greater New York Dental Meeting by August 24, 2024, and failure to submit such description may result in denial of the laser to be shown/demonstrated or denial of exhibit space.

25. REGISTRATION

Each person attending the exhibition is required to promptly register with the Committee and shall, at all times during the exhibition wear the badge issued upon such registration. Any transfer of any such badge is prohibited and, in the event that any such transfer is made, both the individual to whom the badge was issued and the one to whom it was transferred will be compelled to immediately leave the Meeting areas and will be barred from further attendance thereat. Badges are the property of the Committee and are not transferable.

The Exhibitor's representatives at the exhibition shall be limited and restricted to its executives and employees, and then only in such numbers as the Committee, in its judgment, shall deem necessary. Consultants are not considered employees of an Exhibitor. Each of said representatives shall register with the Committee and shall, at all times during the exhibition, wear in conspicuous fashion the badge to be issued upon such registration. The Exhibitor shall not allow or permit any person or persons into its exhibit space, except its said registered representatives.

Exhibiting firms will be permitted to register up to twelve (12) representatives per booth space purchased. Exhibiting companies are allowed to rotate booth staff during the Meeting by returning an Exhibitor badge to Exhibitor registration and requesting a replacement for newly arrived staff who must show proof of employment by the exhibiting firm.

It is expressly understood that, under no circumstances, shall the Exhibitor register a dentist unless he or she is in its full time employ. Any failure or refusal of the Exhibitor to comply with or conform to the provisions of this Paragraph "25" shall constitute a substantial violation of these Rules and Regulations.

26. INTEGRAL PART OF CONTRACT

Each and all of the provisions of these Rules and Regulations shall be deemed to be and constitute an integral part of the Exhibitor's contract for its space at the Meeting, with the same full force and effect as if set forth at length in said contract. The Committee reserves the right to interpret these Rules and Regulations in its sole discretion as well as the right to decide all matters relevant to the Meeting which may not be specifically covered by these Rules and Regulations.

27. DEFAULT

In the event that the Exhibitor shall, at any time after payment to the Committee of the full contract charge for its space at the Meeting, fail to comply with or otherwise violate any of the terms of said contract (including any of the provisions of these Rules and Regulations) on its part to be complied with, then and in that event and in addition to any and all other rights and remedies thereby available to it, the Committee may, at its option, terminate said contract, retain as liquidated damages all sums paid by the Exhibitor thereunder, remove any and all property of said Exhibitor which may be in the exhibition area, and assign the Exhibitor's space to any third party or third parties or use the same for such other purposes as it may deem necessary, all without notice and without further liability to the Exhibitor.

In the event that the Committee shall default (other than by reason of any of the events, occurrences, contingencies or circumstances specified in Paragraph "20" hereof) in complying with the terms of said contract on its part to be complied with, then and in that event its liability to the Exhibitor for any and all damages which the Exhibitor may thereby suffer, sustain or incur shall in no event exceed, and shall for all purposes be limited to, the amount theretofore paid by the Exhibitor to the Committee under the aforesaid contract.

28. GOVERNING LAWS

These Rules and Regulations and the contract with the Exhibitor of which the same form a part shall be governed by, and shall be interpreted and construed under and in accordance with, the laws of The State of New York applicable to agreements executed and to be performed entirely within that State. The Exhibitor hereby consents to the jurisdiction of the courts of The State of New York and the United States District Court for the Southern District

of New York with respect to any matter arising with respect to these Rules and Regulations and the aforesaid contract, shall subject itself to the jurisdiction of such courts and agrees that service of process upon it may be made in any manner permitted by the laws of The State of New York. Without limiting the generality of the foregoing, service of process will be deemed sufficient if sent by registered or certified mail to the Exhibitor at the address set forth in the Exhibitor's contract.

Free New Product Display

We are once again offering free space in the New Product and Technology Pavilion to our 2024 exhibitors. Don't miss the opportunity to have your newest product displayed at the 99th Greater New York Dental Meeting free of charge. This conveniently located pavilion will be easily accessible and visible to all attendees throughout the entire Meeting. Your product will be displayed along with your Company Name and booth number, so attendees can locate your booth on-site for additional information. This Pavilion space is limited and will be assigned on a first-come, first-placed basis. A Listing of new products will also be posted on our website for participating exhibitors.





GREATER NEW YORK DENTAL MEETING®
APPLICATION/CONTRACT FOR EXHIBIT SPACE

GREATER NEW YORK DENTAL MEETING®
200 West 41st Street - Suite 1101
New York, New York 10036-7203
Phone: (212) 398-6922 Fax: (212) 398-6934
E-mail: carla@gnydm.com
Website: www.gnydm.com

100th Annual Session
November 29 – December 4, 2024
Exhibit Dates:
December 1 - December 4, 2024
Jacob K. Javits Convention Center
New York City, New York

Instructions: Type or clearly print. Sign and return the original copy to the above address, with \$1,100.00 deposit per booth, made payable to the Greater New York Dental Meeting. Final payment is due on June 2. Full payment must accompany contract after June 2. Valid Certificate of Insurance is required. Full payment is required for international companies. The company name, address, city, state/country, customer service phone, fax numbers, E-mail and Website address as shown on this form are for use in the Program and Exhibit Guide.

Company Name _____

Address _____ City, State/Country, Zip Code _____

Company Email _____ Company Website _____

Customer Service Telephone () _____ Fax _____

Exhibit Contact Person _____ Email _____ Telephone _____ Fax _____

Advertising Contact Person _____ Email _____ Telephone _____ Fax _____

Sponsorship Contact Person _____ Email _____ Telephone _____ Fax _____

Size of Booth Space required _____ ft. deep x _____ ft. wide Total number of Booths requested _____

Indicate preference [] Standard [] Corner [] Island [] Peninsula [] Pavilion

Number of Booths _____ x \$1,100.00 = Total deposit enclosed \$ _____

Number of Conference Rooms _____ x \$1,100.00 = Total deposit enclosed \$ _____

Number of Executive Suites (only 4 available) _____ x \$1,400.00 = Total deposit enclosed \$ _____

Daily Conference Room _____ 10 x 10 = \$1,150.00/ Daily Conference Room _____ 10 x 20 = \$1,760.00 (early bird rates) \$ _____
11/29 - 1/15

Daily Conference Room _____ 10 x 10 = \$1,170.00/ Daily Conference Room _____ 10 x 20 = \$1,790.00 (until 3/15) \$ _____

Daily Conference Room _____ 10 x 10 = \$1,190.00/ Daily Conference Room _____ 10 x 20 = \$1,800.00 (after 3/15) \$ _____

APPLICATIONS RECEIVED WITHOUT DEPOSIT OR FULL PAYMENT PER BOOTH WILL NOT BE PROCESSED.

If possible, we do not wish to be next to or across from: _____

Provide a brief description of primary products and/or services: _____

PRODUCT CLASSIFICATION: From the classification listing on the reverse side of this application/contract, select the appropriate code numbers for the categories which best describe your products/services. Indicate code for each product description in the space below up to your maximum (See reverse side). Every effort will be made to include company name, company information and product listings on its website and any potential publications, for all applications received prior to September 1st.

- 1. _____ 2. _____ 3. _____ 4. _____ 5. _____
6. _____ 7. _____ 8. _____ 9. _____ 10. _____
11. _____ 12. _____ 13. _____ 14. _____ 15. _____

THE GREATER NEW YORK DENTAL MEETING DOES NOT ASSUME ANY LIABILITY OR RESPONSIBILITY FOR ANY TYPOGRAPHICAL ERRORS, OMISSIONS OR INACCURACIES OF ANY KIND IN ANY OF ITS PUBLICATIONS.

WE AGREE TO ABIDE BY ALL RULES AND REGULATIONS GOVERNING THE MEETING AS PUBLISHED IN THE 2024 EXHIBITORS' PROSPECTUS, WHICH ARE A PART OF THIS CONTRACT AS IF PUBLISHED HEREIN.

AUTHORIZED SIGNATURE _____ TITLE _____ DATE _____

PRINT FULL NAME _____

THE TABLE BELOW INDICATES THE MAXIMUM LISTINGS ALLOWED TO AN EXHIBITOR

1-2 booths...up to 6 product listings
3-4 booths...up to 8 product listings

5-6 booths...up to 10 product listings
7-10 booths...up to 12 product listings

10 or more booths...up to 15 product listings

| | | | |
|---|--|--|---|
| AB03 3D Printing | CU05 Curing Units | IR05 Irrigators | PU02 Publications, Professional & Scientific |
| AB05 Abrasives, Disks/Points/Wheels | DA05 Darkroom Equipment & Supplies | LA05 Laboratory Equipment & Supplies | PU05 Pulp Testers |
| AC05 Acrylics & Accessories | DE05 Dental Dealers | LA07 Lasers | RE05 Record Keeping Systems |
| AI04 Air Abrasives | DE06 Dental Equipment, Mobile/Portable | LA09 Lathes, Chucks | RE06 Refining Resources |
| AI05 Air Compressors | DE07 Dental Hygiene Materials | LA12 Laundry Services | RE08 Repair Kits, Denture |
| AL05 Alloys | DE08 Dental Laboratories | LE01 Leasing | RE09 Repair Services |
| AM05 Amalgamators | DE09 Dental Lab Equipment & Supplies | LI05 Lights, Operating | RE10 Restorative Materials & Accessories |
| AN05 Analgesia/Anesthesia Equipment & Supplies | DE10 Dental Office Design | LI06 Lights, Other | RE11 Retirement Programs |
| AN06 Analgesics | DE12 Dentifrices | LO05 Loupes | RE13 Retraction Materials |
| AN08 Anatomical Models | DE14 Denture Adhesives | LU05 Lubricants | RU05 Rubber Dam & Accessories |
| AN10 Anesthetics | DE15 Denture Base, Reline, Repair Resins | MA05 Marketing Aids & Research | SA05 Saliva Ejectors |
| AN12 Antibacterial Soaps & Detergents | DE16 Denture Cleaners | MA08 Masks | SA10 Saliva, Synthetic |
| AN14 Antibiotics | DI05 Diagnosis & Testing Services | ME05 Medical Waste Services | SC05 Scalars |
| AP05 Apex Locators | DI07 Diagnostic Equipment, All Types & Services | ME07 Medicaments | SC06 Scalars, Ultrasonic |
| AR05 Articulating Paper, Film/Ribbon | DI09 Diamond Points & Disks | ME09 Metal, Recovery & Refining | SH05 Sharpeners, Instrument |
| AR06 Articulators | DI11 Dietary Products | MI05 Microscopes | SL05 Sleep Apnea |
| AS05 Asepsis Products | DI12 Digital Imaging | MI06 Milling Technology | SN01 Snoring Appliances |
| AT05 Attachments | DI13 Digital Impression Taking Systems | MI08 Mirrors (Hand) | SO05 Soaps & Lotions |
| AU05 Audiovisual Equipment & Materials | DI14 Digital Laboratory | MO05 Model Forming Tools & Accessories | SO08 Solder, Fluxes |
| AU08 Autoclaves & Accessories | DI15 Digital Radiography | MO06 Models Demonstration | SK03 Skin Care Products |
| BL02 Bleaching Products | DI16 Disinfecting Solutions | MO09 Mouthwashes (Rinses) | ST05 Sterilizers |
| BL05 Blood Pressure Diagnostic Instruments | DI17 Disks, Mandrels & Strips | NU05 Nutritional Products | ST06 Sterilizer Accessories |
| BO05 Bonding Agents | DI18 Disposable Needles | OF05 Office Equipment, Furniture/Decor | ST07 Sterilizing & Disinfecting Solutions |
| BO07 Bone-Grafting Materials | DI20 Disposable Products | OF06 Office Supplies | ST10 Stools, Lab |
| BO09 Bookkeeping Systems | DR05 Dry Air Systems, Filtration | OP05 Operating Room Supplies & Equipment | ST11 Stools, Operator |
| BO11 Books | ED05 Education Materials | OP06 Optical Aids | SU05 Surgical Supplies |
| BU05 Burs, All Types | EL05 Electrosurgical Equipment | OR05 Oral Hygiene Aids | SU08 Sutures |
| BU07 Business & Finance Service | EM05 Emergency Drugs/Equipment | OR06 Oral Irrigation Devices | SY05 Syringes |
| BU08 Business Systems & Equipment | EN05 Endodontic Instruments & Supplies | OR09 Orthodontic Materials & Accessories | TE02 Technology |
| CA01 Cabinets | EQ05 Equipment Leasing | OS05 OSHA Compliance Products/Services | TE05 Teeth, Artificial |
| CA03 CAD/CAM Materials & Accessories | EQ06 Equipment Repair & Maintenance | OT01 Other | TE08 Telecom, Services & Equipment |
| CA04 CAD/CAM Outsourcing | EV05 Evacuators & Evacuator Systems | PA01 Payroll Services | TM05 TMD Diagnostic & Treatment Products |
| CA05 CAD/CAM Systems | EX05 Exercise Equipment | PA05 Pads, Mixing | TO05 Tooth Shade Guides |
| CA06 Cameras, Extra Oral | EY05 Eyewear, Protective | PA08 Paper Products | TO07 Tooghbrushes, Hand |
| CA07 Cameras, Intra Oral | FI05 Fiber Optic Products | PA10 Patient Financing Services | TO09 Toothbrushes, Power |
| CA09 Casting Machines & Accessories | FI08 Filling Materials & Accessories | PA11 Patient Record Forms | TO12 Torches |
| CA10 Casting Alloys | FI10 Financial Planning & Services | PA21 Patient Education Materials | TO14 Toys & Novelties |
| CE05 Cements, All Types | FL05 Flossing Materials | PE03 Periodicals, Professional/Scientific | TR05 Trays, Impression |
| CH05 Chairs & Accessories | FL08 Fluoride Products | PE05 Periodontal Exam Systems | UL05 Ultrasonic Equipment & Supplies |
| CH08 Chewing Gum | FU05 Furnaces | PE06 Periodontal Materials | UN05 Uniforms, Gowns/Shoes |
| CL05 Claim Processing | FU07 Furniture | PE09 Personnel Services | UN08 Units & Components |
| CL08 Cleansers | GL05 Gloves | PH05 Pharmaceuticals | UP05 Upholstery |
| CO05 Collection Services | GR05 Group Health Plans | PH08 Photographic Equipment & Supplies | VA05 Vacuum Investing Machines |
| CO07 Communication Systems | HA05 Handcare Products & Services | PI05 Pins | VA07 Vacuum Units & Accessories |
| CO09 Composite Instruments & Accessories | HA07 Handpieces, Operating & Laboratory | PI08 Pit & Fissure Sealants | VA10 Varnishes |
| CO11 Composites | IM05 Implant Systems & Devices | PL08 Plating Equipment & Supplies | VI05 Vibrators & Accessories |
| CO15 Computer Hardware/Software | IM07 Impression Materials | PO05 Porcelain Products | WA02 Waterline Filtration Systems |
| CO17 Computer Imaging | IN05 Infection Control Products | PO06 Portable Delivery Systems | WA05 Wax Patterns, Molds/Removers |
| CO10 Cone Beam | IN07 Instruments (Hand), General | PR05 Practice Marketing Services | WA07 Waxes & Accessories |
| CO20 Continuing Education & Training | IN09 Instruments (Hand), Surgical | PR07 Practice Sales | XR05 X-Ray Film & Supplies |
| CO21 Cosmetic Restorations | IN12 Insurance | PR10 Preventive Dentistry Products | XR06 X-Ray Machines & Equipment |
| CO22 Cotton Products | IN14 Interior Decorating | PR12 Prophylaxis Angles & Kits | XR07 X-Ray Processors & Accessories |
| CR05 Crowns and/or Crown & Bridge Materials | IN15 Internet Services | PR13 Prophylaxis Brushes & Cups | ZI03 Zirconia |
| | IN16 Intraoral Video Cameras | PR15 Prophylaxis Materials | |
| | IN18 Investment Materials & Equipment | PR17 Protective Coverings | |
| | IN19 Investment Services | PR21 Prosthetic & Laboratory Supplies | |

| MARCH | | | | | | |
|-------|----|----|----|----|----|----|
| S | M | T | W | T | F | S |
| | | | | | 1 | 2 |
| 3 | 4 | 5 | 6 | 7 | 8 | 9 |
| 10 | 11 | 12 | 13 | 14 | 15 | 16 |
| 17 | 18 | 19 | 20 | 21 | 22 | 23 |
| 24 | 25 | 26 | 27 | 28 | 29 | 30 |
| 31 | | | | | | |

Friday, March 15
Deadline for return of Application/Contract from priority mailing.

| OCTOBER | | | | | | |
|---------|----|----|----|----|----|----|
| S | M | T | W | T | F | S |
| | | 1 | 2 | 3 | 4 | 5 |
| 6 | 7 | 8 | 9 | 10 | 11 | 12 |
| 13 | 14 | 15 | 16 | 17 | 18 | 19 |
| 20 | 21 | 22 | 23 | 24 | 25 | 26 |
| 27 | 28 | 29 | 30 | 31 | | |

Friday, October 11
All finished banners must be received by Freeman.

| JUNE | | | | | | |
|------|----|----|----|----|----|----|
| S | M | T | W | T | F | S |
| | | | | | | 1 |
| 2 | 3 | 4 | 5 | 6 | 7 | 8 |
| 9 | 10 | 11 | 12 | 13 | 14 | 15 |
| 16 | 17 | 18 | 19 | 20 | 21 | 22 |
| 23 | 24 | 25 | 26 | 27 | 28 | 29 |
| 30 | | | | | | |

Sunday, June 2
Exhibitors cancelling before this date will be entitled to a full refund.

| NOVEMBER | | | | | | |
|----------|----|----|----|----|----|----|
| S | M | T | W | T | F | S |
| | | | | | 1 | 2 |
| 3 | 4 | 5 | 6 | 7 | 8 | 9 |
| 10 | 11 | 12 | 13 | 14 | 15 | 16 |
| 17 | 18 | 19 | 20 | 21 | 22 | 23 |
| 24 | 25 | 26 | 27 | 28 | 29 | 30 |
| | | | | | | |

Friday, November 15
Last day for exhibit materials and equipment shipped by or on behalf of the Exhibitor for delivery at the Center for Nov. 29 set-up to be received by Freeman.

Friday, November 29
10:00 A.M. Set up at Jacob K. Javits Convention Center begins.

Saturday, November 30
5:00 P.M. Entire exhibit, with all displays completely set up and ready for inspection.

| JULY | | | | | | |
|------|----|----|----|----|----|----|
| S | M | T | W | T | F | S |
| | 1 | 2 | 3 | 4 | 5 | 6 |
| 7 | 8 | 9 | 10 | 11 | 12 | 13 |
| 14 | 15 | 16 | 17 | 18 | 19 | 20 |
| 21 | 22 | 23 | 24 | 25 | 26 | 27 |
| 28 | 29 | 30 | 31 | | | |

Friday, July 5
Deadline for special electrical wiring.

| DECEMBER | | | | | | |
|----------|----|----|----|----|----|----|
| S | M | T | W | T | F | S |
| 1 | 2 | 3 | 4 | 5 | 6 | 7 |
| 8 | 9 | 10 | 11 | 12 | 13 | 14 |
| 15 | 16 | 17 | 18 | 19 | 20 | 21 |
| 22 | 23 | 24 | 25 | 26 | 27 | 28 |
| 29 | 30 | 31 | | | | |

Sunday, December 1, 9:30 A.M.
Exhibit Hall opens.

Wednesday, December 4, 3:00 P.M.
Exhibit Hall closes. Dismantling of exhibits begins.

Thursday, December 5, 9:00 P.M.
Entire exhibits removed from Exhibit Hall 3E.

Friday, December 6, 10:00 A.M.
Entire exhibits removed from Exhibit Hall 3A/B/D.

| AUGUST | | | | | | |
|--------|----|----|----|----|----|----|
| S | M | T | W | T | F | S |
| | | | | 1 | 2 | 3 |
| 4 | 5 | 6 | 7 | 8 | 9 | 10 |
| 11 | 12 | 13 | 14 | 15 | 16 | 17 |
| 18 | 19 | 20 | 21 | 22 | 23 | 24 |
| 25 | 26 | 27 | 28 | 29 | 30 | 31 |

Thursday, August 1
No refunds or extensions beyond this date.

Application/Contract made after this date must be accompanied by full payment.

Final balance of Exhibit Booth payment due.

End of partial refund period, no refunds after this date.

Monday, August 12
Exhibitors' Manual available on-line.

Friday, August 23
Deadline for the submission of the original Certificate of Insurance, and deadline for notification of intent to use an Exhibitor Appointed Contractor.

MARK YOUR CALENDAR



**THE LARGEST DENTAL MEETING/EXHIBITION/
CONGRESS IN THE UNITED STATES**

JACOB K. JAVITS CONVENTION CENTER, NEW YORK CITY

**GREATER
NY
DENTAL MEETING**

WWW.GNYDM.COM

FUTURE MEETING DATES

2025

**MEETING DATES:
NOVEMBER 28-DECEMBER 3**

**EXHIBIT DATES:
NOVEMBER 30-DECEMBER 3**

2026

**MEETING DATES:
NOVEMBER 27-DECEMBER 2**

**EXHIBIT DATES:
NOVEMBER 29-DECEMBER 2**

2027

**MEETING DATES:
NOVEMBER 26-DECEMBER 1**

**EXHIBIT DATES:
NOVEMBER 28-DECEMBER 1**

